

MULTISTANDARD MULTIMODE DIGITAL & ANALOG TERRESTRIAL TV TRANSMITTER LINE

The high quality, professional and cost-effective solution

FEATURES:

- A high performance digital & analog Multi-standard Multimode TV Transmitter Line featuring latest technology
- High reliability with choice of dual drive, passive stand-by or n+1 systems
- Low power consumption
- Low cost of ownership, low capital cost, running expenses & maintenance

ANALOG

DVB-T/H

DVB-T2

ISDB-T/Tb

ATSC

DVB
Digital Video
Broadcasting



ABE Elettronica is proud to present the "MTX" Series of Transmitters – Transposers - Gap-fillers for Analog and Digital Terrestrial Television Broadcasting (DVB-T/H, DVB-T2, ISDB-T/Tb, ATSC and other standards).

With the company's 30 years of experience in this field, the "MTX" Series is the ultimate in technology, quality and performance; it is

designed to take advantage of the excellence of the digital modulation systems to generate both Analog and Digital emissions. This new "MTX" series of Transmitters – Transposers - Gap-fillers brings together the highly efficient and reliable ABE MOS and LD-MOS broadband Power Amplifiers with state-of-the-art technological solutions.



The “MTX” is a **Multistandard Multimode** terrestrial TV broadcasting transmitter series.

It incorporates the “MTX” professional grade driving unit able to support both **analog and digital standards** (please see specific documentation for detailed description).

Featuring modulator construction – with easily removable modules having RF internal isolation – the MTX series exploits the advantages of state of the art technological solutions to achieve high reliability and comprehensive system flexibility – all at reduced size. Maintenance as well as channel changing operations are simple and easy to perform.

Careful product design brings high versatility, enhanced by the provision of specific options and giving **compliance with major world digital and analog terrestrial TV broadcasting standards**.

Equipment employ high performance, highly efficient power amplifiers (low power consumption in comparison with the output power), using **MOS** and/or **LD-MOS** semiconductors, AB class polarized, properly **precorrected** in order to obtain the necessary linearity.

In the high power amplifiers, efficiency is further enhanced by the use of **switched-mode power supplies**, provided with **PFC-Power Factor (cos. ϕ) Corrector** in order to minimize reactive power consumption.

With digital signals, the power stages are “backed-off” (derated) to an output power which is typically 3 to 6 dB less their analog combined TV signal rating.

The solid-state high power output amplifiers normally comprise more independent power amplifiers chassis, each with its own power supplies.



Should a failure affect the output from one power amplifier chassis, the other one will continue to work normally at full power, transmission therefore continues at reduced power but, importantly, the emission remains “on-air”.

With the optional “**Dual-Drive**” configuration there is an **Automatic Changeover Unit** which, in the event of low RF power from the working Drive, immediately brings the stand-by optional Drive into operation and ensures that transmission will continue at full power.

Alternatively it is possible to provide a complete **automatic passive stand-by system** that can operate in redundant configurations (**1+1** and/or **n+1**).

These features ensure a high degree of operational reliability. Essential maintenance is also facilitated.

Example of Transmitter configuration

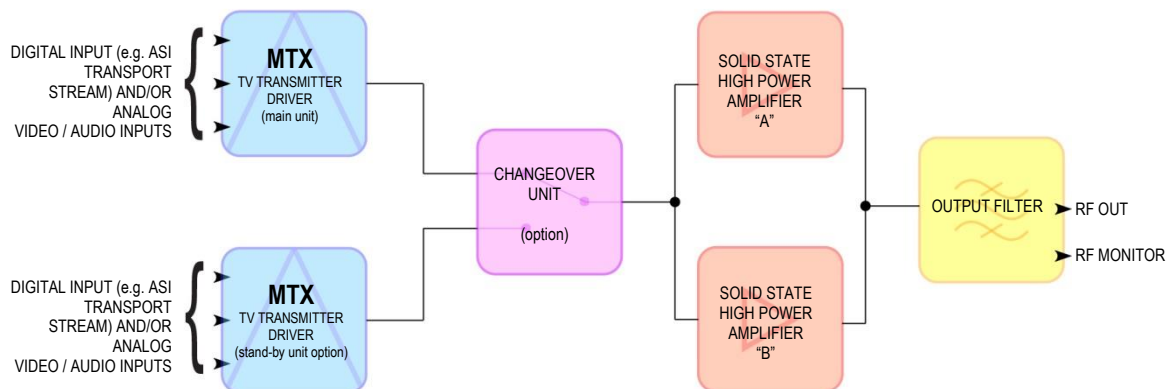

GENERAL FEATURES AND OPTIONS:

- Comprehensive monitoring, alarm and protection circuits, including a Power Amplifier **fold-back** function to reduce output power before tripping off, due to high VSWR, heat-sink over-temperature or overdrive
- **Warm-up & Soft-start** functions to avoid output power surges
- **ALC** (Automatic Level Control) to stabilize the Power Amplifier's RF output level over a limited range
- Power Amplifier Modules with gain and phase⁽¹⁾ adjustment to obtain **perfect matching** when coupling more units
- Efficient air cooling system with long life blowers and ducted air outlet; option for ducted air inlet
- **Output filters** to comply with the emission mask specification requested
- **"MTX"** Multistandard Multimode **driving unit** allow **dualcast operation** (analog and digital multistandard) and can be supplied with various options and in several configurations to satisfy Customer's need (wide choice of input interfaces, **linear and non-linear precorrection** with option for **adaptive...** - please see specific documentation for detailed description, features and technical specifications)
- **Dual-Drive** option include a stand-by Drive unit and the Automatic Changeover unit which, in the event of fail of the working Drive, immediately brings the stand-by Drive into operation
- User Friendly **local and remote control** includes "on-board" display, WEB server, SNMP and e-mail client

⁽¹⁾- phase adjustment for UHF only



3.5kW Digital TV Transmitter
High efficiency – Ducted Cooling version



"MTX" SERIES: TAKE ADVANTAGE OF ANALOG TV TRANSMITTERS WITH DIGITAL PROCESSING

- Improved performance as digital processing introduces less noise and distortion and does not require any adjustment, calibration or re-calibration
- Several additional features and many more possibilities (e.g. built-in video test generator, linear and non-linear digital pre-correction, flexibility in modifying and correcting input and output signals, etc.)
- The same hardware to switch to digital modes, thus having a truly "digital ready" transmitter
- Greater ease of on-site upgrade

MTX Series Standard specification

Output frequency range:	VHF or UHF (according to the model)
Output impedance:	50Ω
Spurious, harmonics and out of channel + upper and lower adjacent channel IMD products:	≤ -60dB (with RF output filter)
Frequency stability (in the range -5 to +45°C):	≥ ±250Hz (option: GNSS locked reference for better than 1Hz stability)

DIGITAL OPERATION SPECIFICATIONS

Output power:	0.5W to 10KWavg (tol.+0/-1dB) according to the model (before output filter)
Transmission standard:	OFDM (DVB-T/H; DVB-T2; ISDB-T/Tb); 8VSB (ATSC); other on request for detailed specifications see driver specific documentation
Intermodulation products (shoulders) just outside channel edges (before output filter):	According to the model and power output (typ. Spec. ≤38dB with reference to emission channel centre power density)
MER – Modulation Error Ratio:	According to the model and power output (typ. Spec. ≥35dB)
Input interface options:	ASI; Ethernet (T.S. over IP); DVB-S/S2 multistream receiver; terrestrial receiver (for different input interfaces and specifications, see driver specific documentation)

ANALOG OPERATION SPECIFICATIONS

Output power:	1W to 20KW (tol.+0/-1dB) according to the model (including output filter loss)
Transmission standard:	B, G, D, H, I, K, K1, M or N
In band intermodulation products	≤ -60dB (typical; max. -56dB – Test: V.C. -8dB; S.C. -10dB; C.S. -16dB)
Video input:	1Vpp (75Ω BNC-f) – video processing include ALC and signal reconstruction
Transmitted Video quality parameters:	Differential gain: within ±1.5% (typical; max.±5%); Differential phase: ±1.5° (typical; max.±3°) 2T K rating: 1% (typical; max 2%); Random noise (weighted typical): ≥60dB; Group delay response (V.C. to C.S.): Within ±40nS Amplitude / frequency response: (V.C. to C.S.): Within ±0.5dB (typical; max. ±1dB)
Audio input:	0dBm (adjustable) 600 Ω bal. / unbal.
Audio options:	Stereo / dual sound IRT; BTSC; other on request
Transmitted Audio quality parameters:	Amplitude / frequency response: ±0.5dB (typical; max. ±1dB); Harmonic distortion: ≤0.4%

GENERAL SPECIFICATIONS

Power supply:	According to the model: 90 to 264 Vac single phase or 207 to 415 three phases 50/60Hz
Remote control interface options:	RS485; Ethernet 10/100 Base-T (SNMP - web server - e-mail client) Remote firmware upgrade: supported
Housing:	Standard rack 19"
Operating temperature range:	-5 to +45°C
Maximum operative humidity:	90% non condensing

MAIN AVAILABLE OPTIONS:

- Output Filters to comply with specific emission masks (e.g.: critical or non critical OFDM mask, ATSC A64 mask, etc.);
- RF Multiplexers to combine more transmitters on the same antenna;
- Dual Drive;
- Multiple Power Amplifiers;
- Passive stand-by systems (1+1 or n+1 configurations)



All specifications contained in this document may be changed without prior notice.